



# Fire Alarm System



# Addressable Fire Alarm System

## Features

The Mega-Guard Fire Alarm System (FAS) is available in two different versions: an addressable and a conventional marine fire alarm system. This section describes the addressable Fire Alarm System. The addressable FAS monitors up to 8 different loops on the ship in compliance with EN54-2 and type approved by classification societies. A single loop supports up to 120 addressable fire detectors divided in up to 16 zones. The Mega-Guard addressable FAS supports a maximum of 480 fire detectors. Each detector is individually monitored and configured by the addressable Fire Alarm System.

A total of 16 different fire detectors are available in order to suit all marine applications. The Mega-Guard addressable FAS is powered by two 19~32VDC power supplies: one main supply and one back-up supply.

Mega-Guard FAS Operator Panel	
Touchscreen	5,7"
Pushbuttons	6
Front	metal or glass
Microprocessor	ARM
Ethernet ports	4
Number of detectors	480
Number of FAS Controllers	4
Number of zones	32

Mega-Guard Addressable FAS Controller	
Number of loops	2
Number of detectors	120 each loop
Power supply	24VDC (-25% ~+30%) main and back-up

FAS environmental and approvals	
Ambient temperature	-25 ~ 70°C
IMO approval	✓
Class approval	LRS,DNV-GL, ABS RINA, BV, RMRS, CCS, NKK, PRS, KR



FAS Operator Panel with a Fire Alarm and a Loop Fault

## System lay-out and operation

The Mega-Guard addressable FAS consists of the following items:

- ▶ **FAS Operator Panel** for flush panel mounting in bridge console
- ▶ **Addressable FAS Controller** for din-rail mounting inside bridge console
- ▶ **Addressable Detectors** connected to the FAS Controller
- ▶ **I/O Cable** connecting the FAS Operator Panel with FAS Controller

The FAS Operator Panel is operated through a user friendly 5,7" touchscreen for intuitive operation and monitoring. This Operator Panel is available in two different versions, a panel with a metal front for commercial and navy ships and a panel with glass front for mega yachts. The FAS Operator Panel has two operating levels; one accessible for all crew members and a second level which is only accessible for authorized crew members via entering a password. The Addressable FAS Controller is DIN rail mounted inside bridge console and the detectors are wired in a loop and connected to this Controller.

Addressable Detectors have their own address so that the Mega-Guard addressable FAS is able to distinguish each individual detector.

The I/O Cable with length of 3 or 5 meter, inter-connects the FAS Operator Panel with the FAS Controller.

## Fire Alarm procedure

A Fire Alarm is generated when one or more of the FAS detectors comes into alarm condition. The Fire Alarm System is able to distinguish all individual detector alarms.

The Fire Alarm procedure is as follows:

- ▶ Activation of: Fire Alarm lamp, internal buzzer (2Hz), external Siren (continuous) and identification of detector in alarm on the FAS Operator Panel.
- ▶ When Stop Horn is pressed in Level 2 the internal buzzer and external siren are silenced. This function is also available in Level 1 when selected during installation.
- ▶ When Reset pressed in Level 2 the system is reset. Fire Alarm lamp will extinguish and detector alarm on touchscreen will be cleared when fire alarm condition has disappeared.

## Fault Alarm procedure

A Fault Alarm is generated when one of following conditions:

- ▶ Loop fault
- ▶ Earth fault
- ▶ Siren fault
- ▶ Main or back-up supply failure

The Fault Alarm procedure is as follows:

- ▶ Activation of: Fault Alarm lamp, internal buzzer, external Siren (when selected during installation) and identification of fault on the FAS Operator Panel.
- ▶ When Stop Horn is pressed in Level 2 the internal buzzer and external siren are silenced. This function is also available in Level 1 when selected during installation.
- ▶ When automatic Reset selected during installation, the FAS returns to normal condition in case fault disappears
- ▶ When manual Reset is selected during installation, the FAS will return to normal condition after pressing Reset when fault disappears.

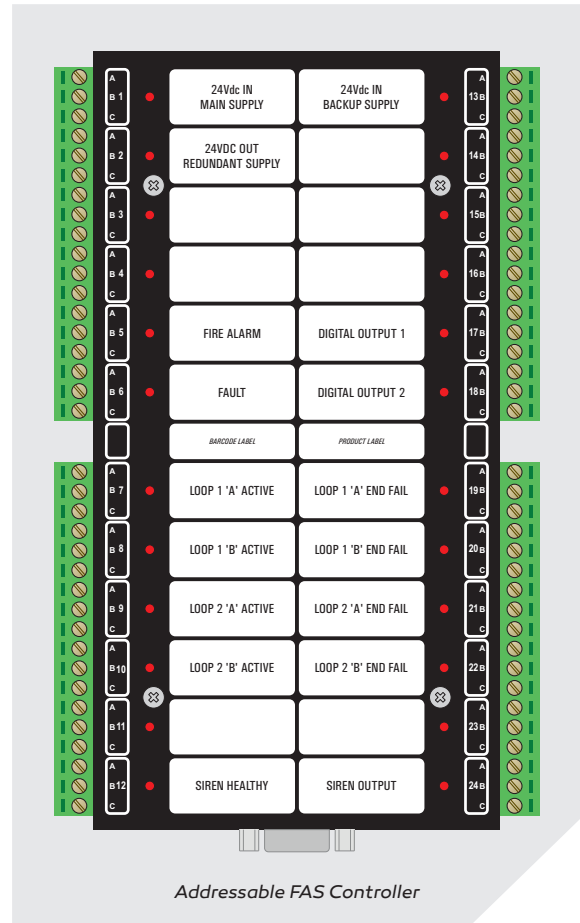

## Mounting & dimensions

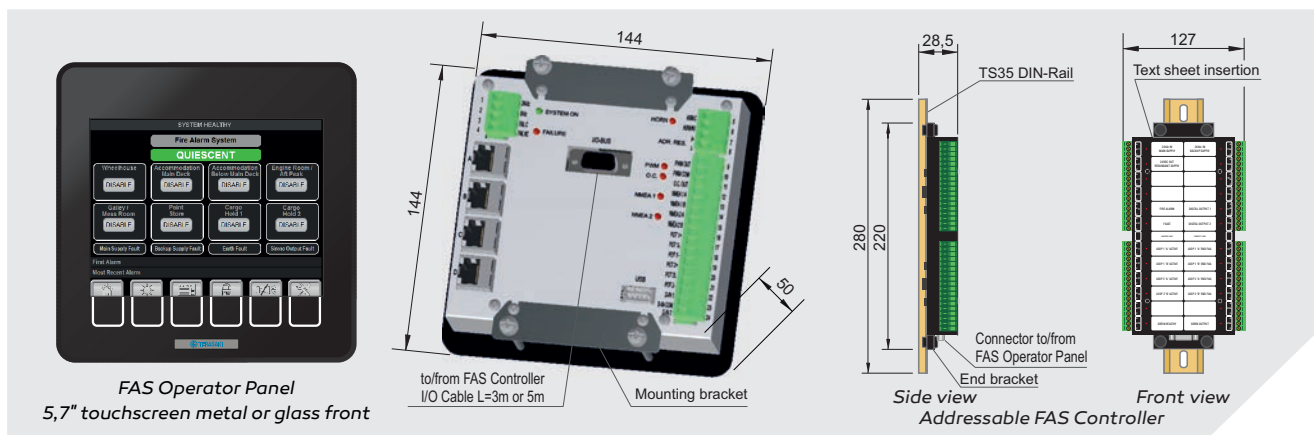

# Addressable FAS lay-out



Smoke Detector



Heat Detector



Multi Sensor Detector

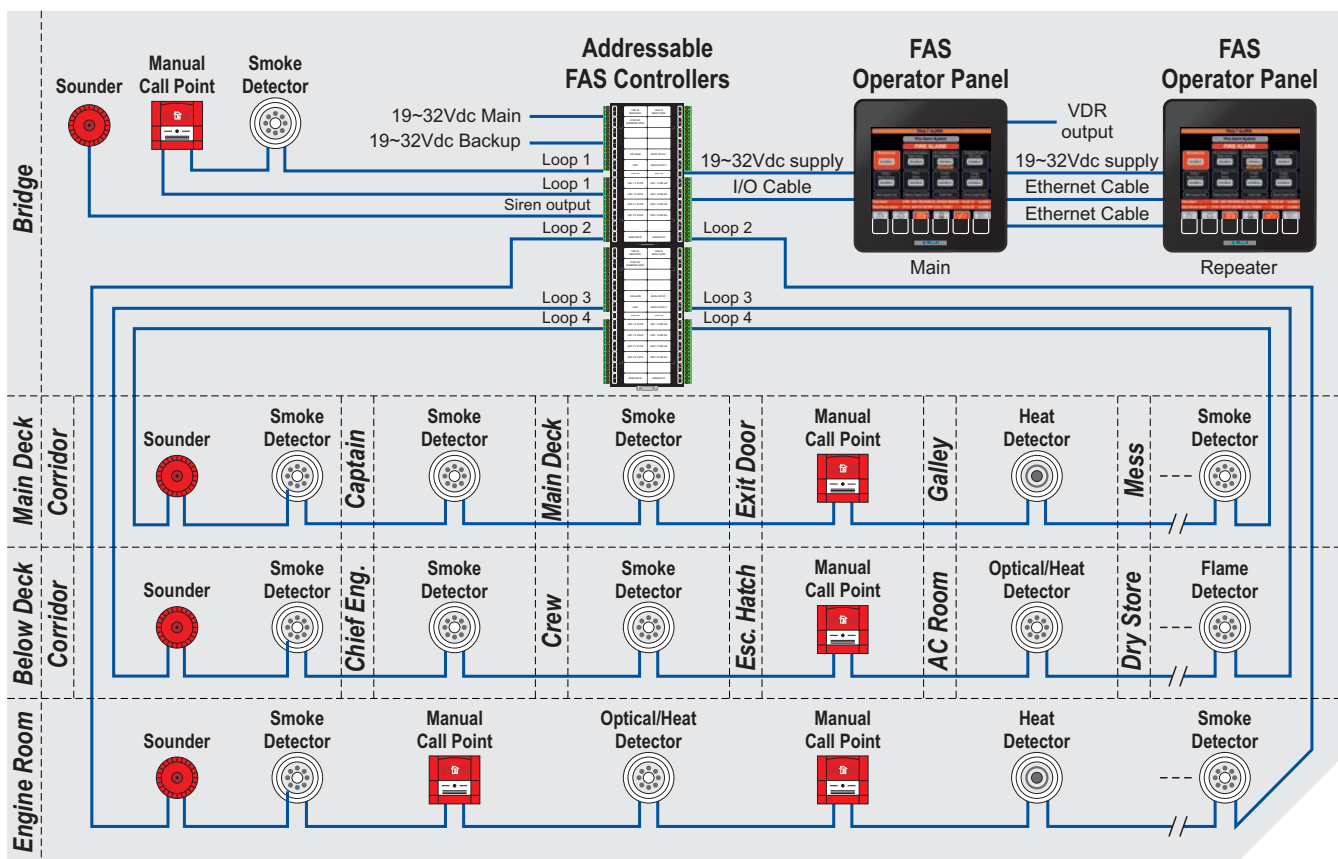

## Mega-Guard Addressable FAS Detectors

Type	Model	Base	Location
Optical smoke detector	P600MAR	P210MAR	Bridge, control room, machinery spaces, accommodation
Ionisation smoke detector	P500MAR	P210MAR	Bridge, control room, machinery spaces, accommodation
Heat detector	P400MAR	P210MAR	Bridge, control room, accommodation, open deck, smoking area
Optical smoke / Heat detector	P700MAR	P210MAR	Bridge, control room, machinery spaces, accommodation
UV Flame detector	PO27MAR	-	Machinery spaces, open deck
Manual call point *	P970MAR	-	Bridge, control room, machinery spaces, accommodation
Manual call point IP67 *	P975MAR	-	Machinery spaces, open deck
Isolator	P721 MAR	P211MAR	Bridge, control room, machinery spaces, accommodation

\* Manual call points can also be delivered including Isolator

# Conventional FAS lay-out

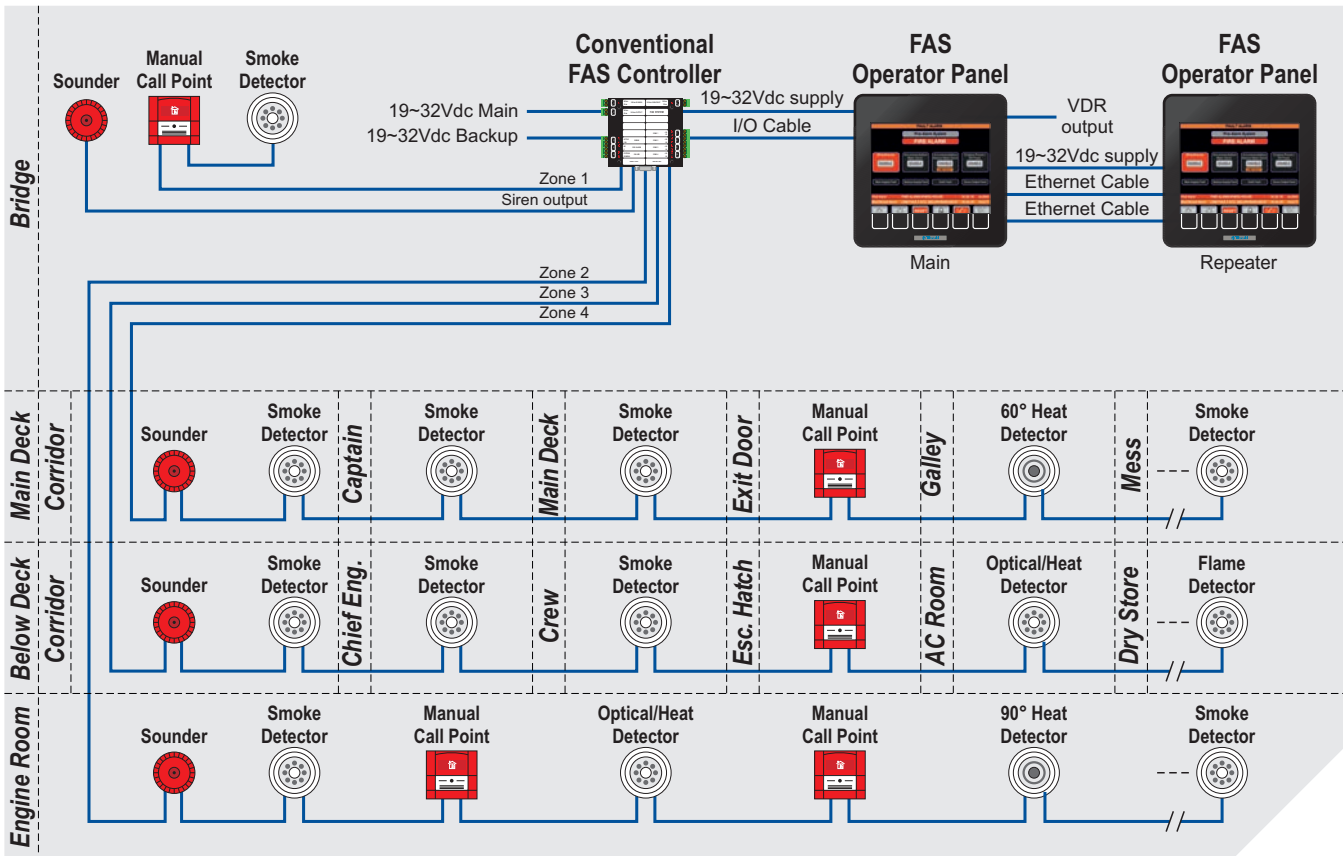

## Mega-Guard Conventional FAS Detectors

Type	Model	Base	Location
Optical smoke detector	P42001MAR	P0001MAR	Bridge, control room, machinery spaces, accommodation
Heat detector BR rate of rise	P41003MAR	P0001MAR	Bridge, control room, open deck
Heat detector BS 60degr	P41004MAR	P0001MAR	Bridge, control room, accommodation
Heat detector CS 90 degr	P41006MAR	P0001MAR	Machinery spaces, open deck
Optical smoke / Heat detector	P43001MAR	P0001MAR	Bridge, control room, machinery spaces, accommodation
UV Flame detector	PO26MAR	-	Machinery spaces, open deck
Manual call point	PO21MAR	-	Bridge, control room, accommodation
Manual call point IP67	PO22MAR	-	Machinery spaces, open deck

Other types available on request

# Conventional Fire Alarm System

## Features

The Mega-Guard Fire Alarm System (FAS) is available in two different versions: an addressable and a conventional marine fire alarm system. This section describes the conventional Fire Alarm System.

The conventional FAS monitors up to 4 different zones on the ship in compliance with EN54-2 and type approved by classification societies.

A single zone supports up to 32 conventional fire detectors.

The Mega-Guard conventional FAS supports a maximum of 128 fire detectors. Each zone is individually monitored and a distinction can be made in between Heat/Smoke Detectors and Manual Call Points.

A total of 16 different fire detectors are available in order to suit all marine applications. The Mega-Guard conventional FAS is powered by two 19~32VDC power supplies: one main supply and one back-up supply.



Mega-Guard FAS Operator Panel	
Touchscreen	5.7"
Pushbuttons	6
Front	metal or glass
Microprocessor	ARM
Ethernet ports	4
Number of detectors	128
Number of zones	4

Mega-Guard Conventional FAS Controller	
Number of zones	4
Number of detectors	32 each zone
Power supply	24VDC (-25% ~+30%) main and back-up

FAS environmental and approvals	
Ambient temperature	-25 ~ 70°C
IMO approval	✓
Class approval	LRS,DNV-GL, ABS RINA, BV, RMRS, CCS, NKK, PRS, KR

## System lay-out and operation

The Mega-Guard addressable FAS consists of the following items:

- ▶ **FAS Operator Panel** for flush panel mounting in bridge console
- ▶ **Conventional FAS Controller** for din-rail mounting inside bridge console
- ▶ **Conventional Detectors** connected to the FAS Controller
- ▶ **I/O Cable** connecting the FAS Operator Panel with FAS Controller

The FAS Operator Panel is operated through a user friendly 5,7" touchscreen for intuitive operation and monitoring. This Operator Panel is available in two different versions, a panel with a metal front for commercial and navy ships and a panel with glass front for mega yachts. The FAS Operator Panel has two operating levels; one accessible for all crew members and a second level which is only accessible for authorized crew members via entering a password. The Conventional FAS Controller is DIN rail mounted inside bridge console and the detectors are wired in parallel and connected to this Controller. Conventional Detectors in a single zone cannot be extinguished from each other; except for Manual Call Points.

The I/O Cable with length of 3 or 5 meter, inter-connects the FAS Operator Panel with the FAS Controller.

## Fire Alarm procedure

A Fire Alarm is generated when one or more of the FAS detectors (heat/smoke/flame/manual call point) comes into alarm condition. The Fire Alarm System is able to distinguish all individual zone alarms.

The Fire Alarm procedure is as follows:

- ▶ Activation of: Fire Alarm lamp, internal buzzer (2Hz), external Siren (continuous) and identification of zone in alarm on the FAS Operator Panel.
- ▶ When Stop Horn is pressed in Level 2 the internal buzzer and external siren are silenced. This function is also available in Level 1 when selected during installation.
- ▶ When Reset pressed in Level 2 the system is reset. Fire Alarm lamp will extinguish and detector alarm on touchscreen will be cleared when fire alarm condition has disappeared.

The internal buzzer and external siren can be activated again in Level 2 by pressing Stop Horn for more than 2 seconds.

## Fault Alarm procedure

A Fault Alarm is generated when one of the following conditions occurs:

- ▶ Loop fault      ▶ Earth fault
- ▶ Siren fault     ▶ Main or back-up supply failure

The Fault Alarm procedure is as follows:

- ▶ Activation of: Fault Alarm lamp, internal buzzer, external Siren (when selected during installation) and identification of fault on the FAS Operator Panel.
- ▶ When Stop Horn is pressed in Level 2 the internal buzzer and external siren are silenced. This function is also available in Level 1 when selected during installation.
- ▶ When automatic Reset selected during installation, the FAS returns to normal condition in case fault disappears
- ▶ When manual Reset is selected during installation, the FAS will return to normal condition after pressing Reset when fault disappears.

## Mounting & dimensions

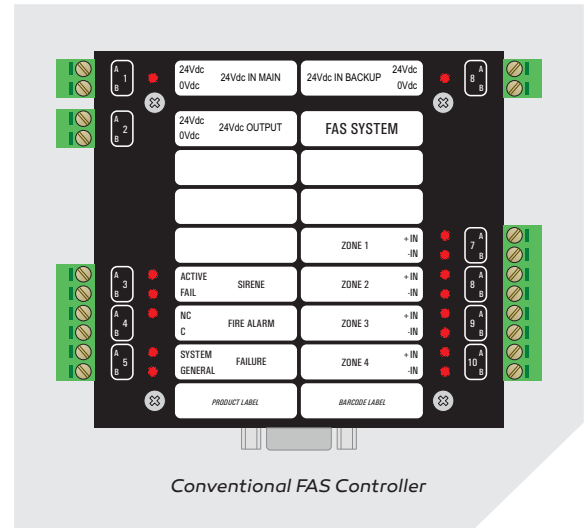
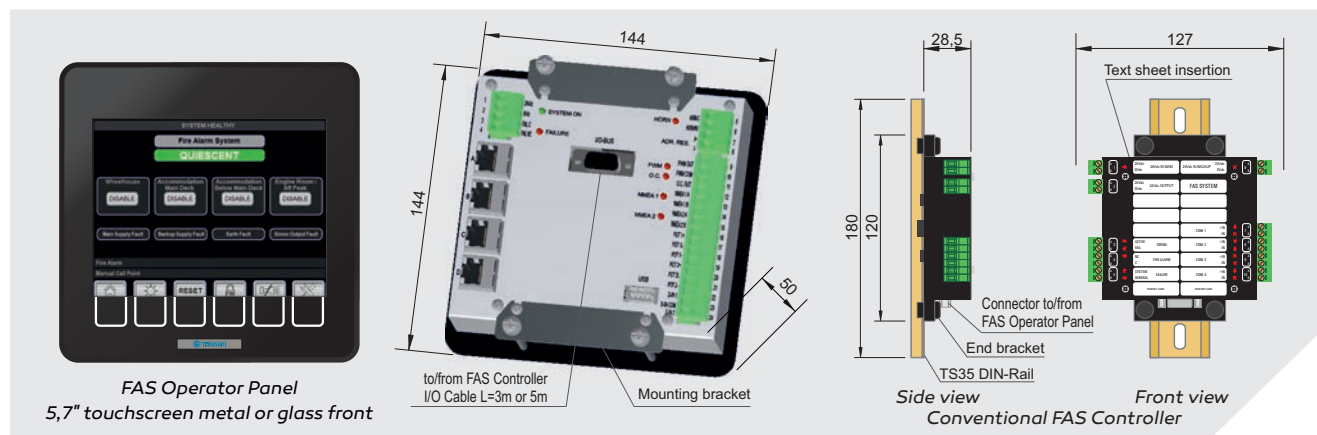

Vessel Management System



Power Management System



BNWAS Watch Alarm System



Navigation Light Control



Wiper Control System



Fire Alarm System



Ship Performance Monitor



Fleet Management System



## Ship automation

### **Terasaki Electric Co., (Far East) Pte Ltd**

17, Tuas Street, Singapore 638454

Phone (+65) 65611165, Fax (+65) 65612166, Email [tefe@terasaki.com.sg](mailto:tefe@terasaki.com.sg), Web [www.terasaki.com.sg](http://www.terasaki.com.sg)

### **Terasaki Electric Group China Sales Main Office**

Room No.1405-06, Tomson Commercial Building, 710, Dong Fang Road, Pudong, Shanghai, China 200122

Phone (+86) 21 58201611, Fax (+86) 21 58201621, Email [terasaki@vip.163.com](mailto:terasaki@vip.163.com)

### **Terasaki Electric Co., (Shanghai) Co Ltd**

Building 567, No.399 Xuanzhong rd. Nanhui Industrial Zone, Shanghai, China 201314

Phone (+86) 21 58186340, Fax (+86) 21 58186350, Email [tsc@terasaki.com.cn](mailto:tsc@terasaki.com.cn), Web [www.terasaki.com.cn](http://www.terasaki.com.cn)

### **Terasaki Electric (China) Ltd**

72, Pacific Industrial Park, Xintang, Zengcheng, Guangzhou, China 511340

Phone (+86) 20 82708556, Fax (+86) 20 82708586, Email [Terasaki-tcssales@vip.163.com](mailto:Terasaki-tcssales@vip.163.com), Web [www.terasaki.cn](http://www.terasaki.cn)